

Freestanding Tub

Luxart®
VitaBella

Product Specifications

LUXART®
ATANIA®

Luxart VitaBella tubs are made of mineral composite, an organic mixture of ground natural minerals and binding agents that are liquefied, poured and then hardened. The result is molded stone, solid through and through with no layers, hollow or void areas and a deep-soak bath experience unlike any other.



TECHINCAL SPECIFICATIONS

Height	22 in
Width	28-1/4 in
Depth	15-3/4 in
Length	63-1/2 in
Weight	244.05 pounds
Shipping Weight	308.65 pounds
Capacity (full)	67 Gallons
Capacity (to overflow)	53 Gallons
Drain	Center
Overflow	Integrated
Faucet Type	Wall or Floor Mount

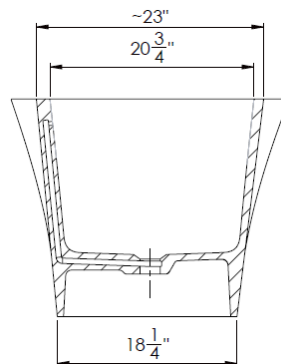
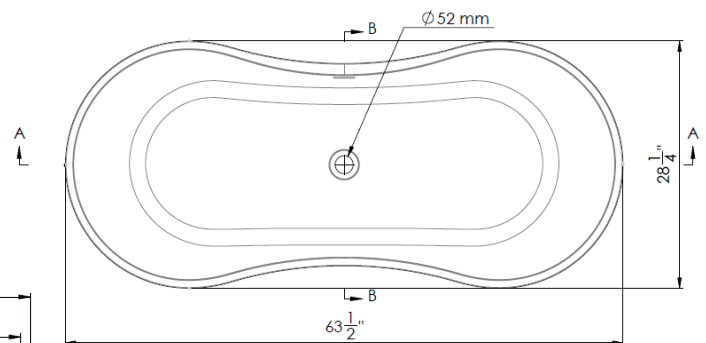
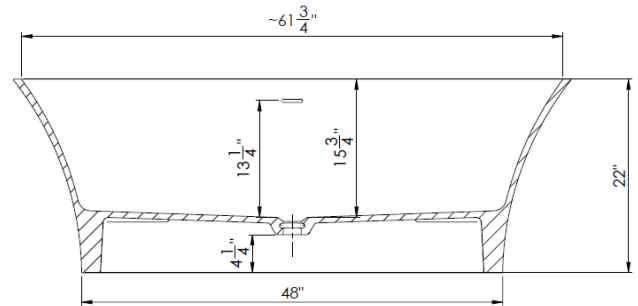

APPLICABLE STANDARDS/CODES

Specified model meets or exceeds the following:

- IAPMO/cUPC

AVAILABLE FINISHES:

- Gloss Finish – ATANIA6328OF
- Matte Finish – ATANIA6328OFM



Contact your sales representative for more information or visit our website at luxartcollection.com

Freestanding Tub

Luxart®
VitaBella

Product Specifications

TECHINCAL SPECIFICATIONS

ABS Intergral Bath Tub Drain Assembly shall feature a Brass coarse thread strainer with 5/16-18 UNC thread-in crossbar and Integral overflow holes with vertical weeping channels. ABS fitting features an 1-1/2" DWV Hub.

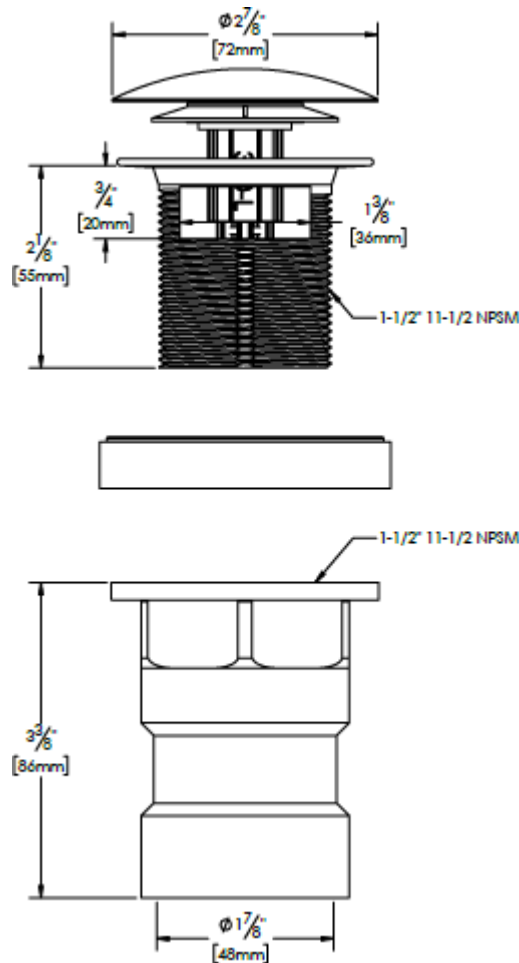

Contact your sales representative for more information or visit our website at luxartcollection.com

Revised 9/18/2023